

Pure Water Desalinators

Custom Configurations

800 - 2000 GPD

3.0 - 7.5 m³/day



For Commercial Marine Applications

Racor Village Marine offers the proven components of the industry standard PW Series Watermakers in varied formats to fit special installation requirements.

The PWV vertical style requires a very small footprint space. The PWS “swing” semimodular style has a hinged front panel to allow service access to all components from the front.

Both formats include media prefiltration and automatic flushing standard.

Contact Information:

Parker Hannifin Corporation
Racor Division/Village Marine Tec.
2000 W. 135th St.
Gardena, CA 90249

phone 310 516 9911
fax 310 538 3048
racor@parker.com
www.villagemarine.com

www.parker.com/racor



VMT PWV-2000



VMT PWS-2000 “Swing”

(Boost pump, media filter and membrane rack supplied as separate components)



Aqua Pro[®] Pump 708-5

Key Feature:

At the core of each PW Series Watermaker is the Aqua Pro[®] 5 plunger high pressure pump:

- Titanium head for maximum corrosion resistance
- Balanced drive for lowest noise and pulsation
- Ceramic Plungers and nylon valves for long service life

ENGINEERING YOUR SUCCESS.

Pure Water Desalinators

Custom Configurations
800 - 2000 GPD
3.0 - 7.5 m³/day

Features:

- Monel mesh strainer and dual sediment prefilters

- Multi-media prefilter including controls for backwash and rinse
- Low RPM five plunger titanium pump for minimum vibration and noise with unsurpassed corrosion resistance
- Nickel Aluminum Bronze feed provides boost pressure to the filtration system
- Stainless steel, glycerin filled pressure gauges
- Automatic freshwater flush system included
- Adjustable 316 SS pressure regulating valve allows use in fresh, brackish or seawater
- Easy to operate 316 SS high pressure bypass valve controls the operating mode and allows high pressure bypass for start-up and low pressure flushing without readjustment of regulating valve

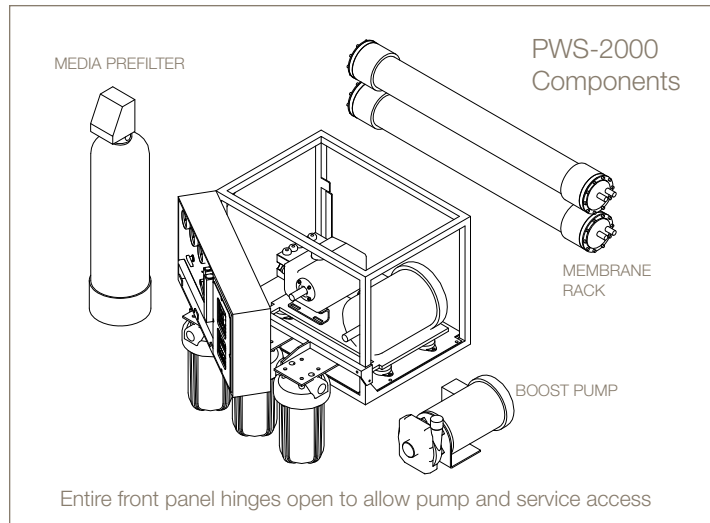

Model	Part Number	Capacity GPD m ³ /day	Power Volts/Phase/Hz/Amps	Dimensions inch/cm	Weight lbs/kg
PWV-800	90-8253 90-8220 90-8287	800 3.0	220/1/60/25 440/3/60/6.5 380/3/50/7	31/79 Wide 22/56 Deep 56/142 High	509/231
PWV-1200	90-8650 90-8651 90-8286	1200 4.5	220/1/60/25 440/3/60/6.5 380/3/50/7	31/79 Wide 22/56 Deep 56/142 High	526/239
PWV-2000	90-8652 90-8275	2000 7.5	440/3/60/10 380/3/50/10	31/79 Wide 24/61 Deep 56/142 High	556/253
PWS-1200	90-8288 90-8289	1200 4.5	440/3/60/6.5 380/3/50/7	Frame W x D x H 27/69 x 24/61 x 16/41 Prefilters extend 14/35 below frame. Boost pump, Media Filter and Membranes are modular	526/239
PWS-2000	90-8612 90-8290	2000 7.5	440/3/60/10 380/3/50/10		556/253

To maintain peak performance always use genuine Parker-Racor/Village Marine Tec. replacement parts. We reserve the right to change our specifications or standards without notice.